



BEFORE YOU BEGIN TO READ THE WIND.  
BEFORE YOU BEGIN TO READ THE WATER.  
BEGIN BY READING THIS RIGGING GUIDE.



Congratulations on the purchase of your new Nomad! We suggest that you read through this guide to better familiarize yourself with the parts and rigging of your new boat. If you have any questions please contact your dealer or call Vanguard's customer service at 1-800-966-SAIL.

First locate your delivery kit. Using image one and two, identify the contents of your kit. To avoid damaging the contents, be sure not to cut into the packaging inside the box.

Image 1

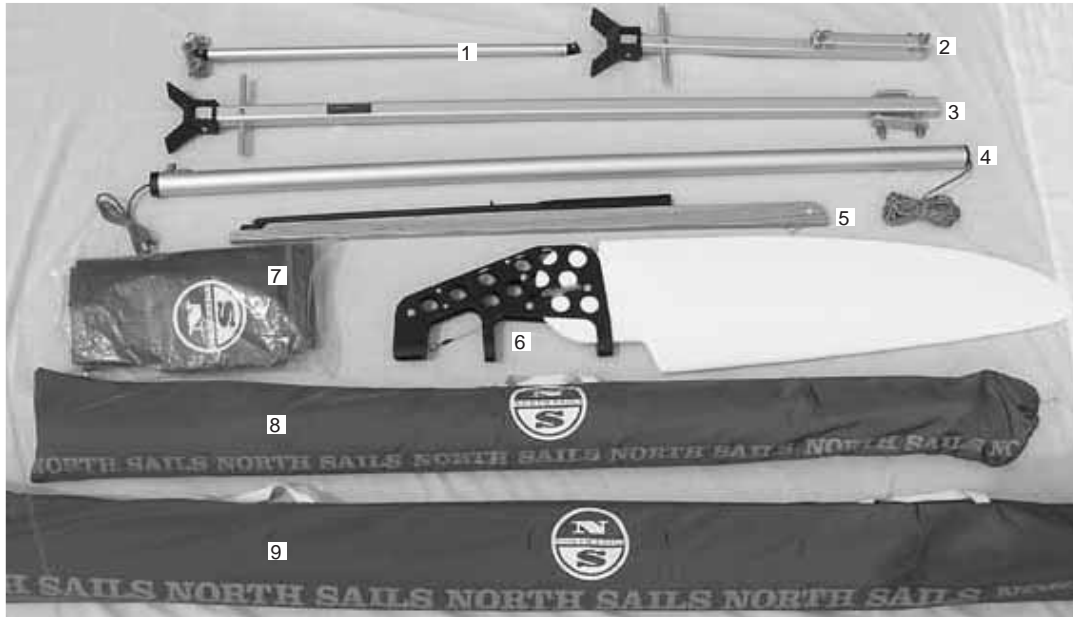

**Unpacking and preparation:**



Image 2

**Contents of Image 1:**

- |                         |                          |
|-------------------------|--------------------------|
| 1. Gnav Strut           | 5. Tiller with Extension |
| 2. Aft Mast Carrier     | 6. Rudder                |
| 3. Forward Mast Carrier | 7. Spinnaker             |
| 4. Bow Sprit            | 8. Jib                   |
|                         | 9. Mainsail              |

**Contents of Image 2:**

- |                    |                              |
|--------------------|------------------------------|
| 1. Sail Numbers    | 3. Ratchet Blocks (3)        |
| 2. Line Bag        | 4. Furler Drum               |
| a. Main sheet      | 5. Shackle with pin and ring |
| b. Jib sheets (2)  |                              |
| c. Spinnaker sheet |                              |
| d. Furler line     |                              |

Here is a list of tools that we recommended you have to assist you in assembling your new Nomad:



Utility Knife



Flat Head and Phillips Head Screwdriver



Adjustable Wrench or Crescent Wrench



2 Pairs of Pliers



Electrical Tape

Useful Knots to Know:



Figure 8 Knot or Stopper Knot



Square Knot



Bowline



Clove Hitch



Cleat

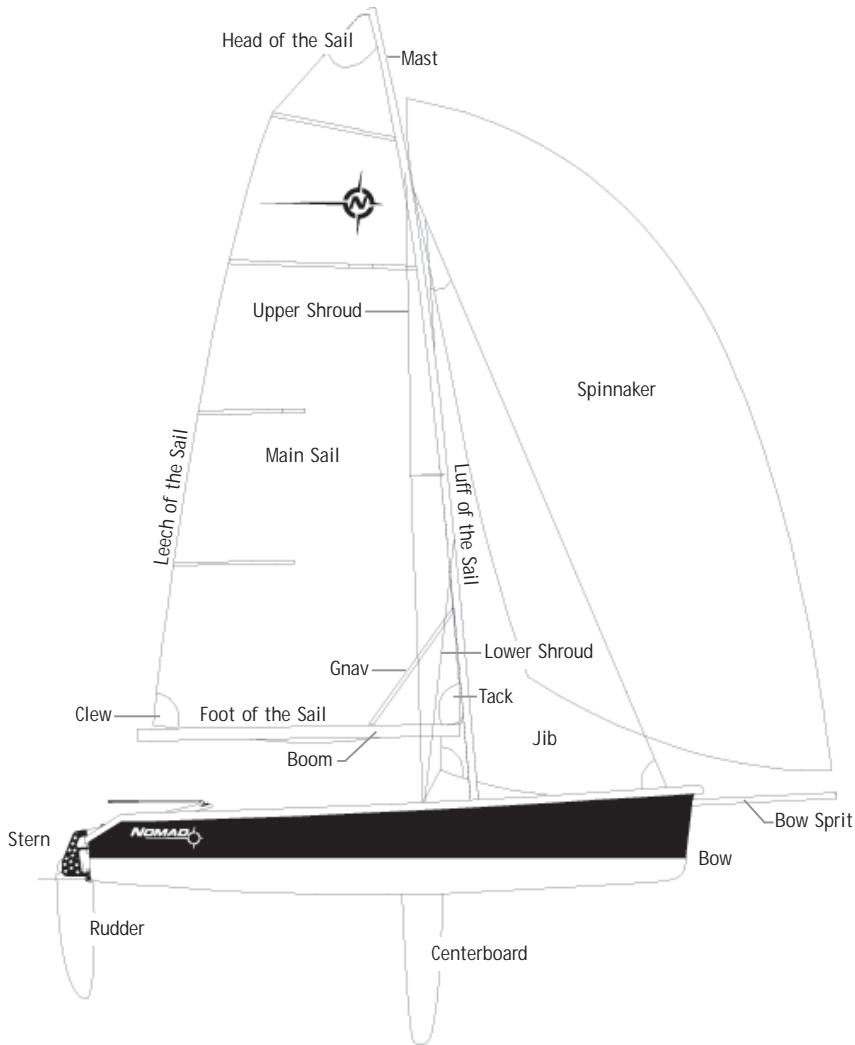

**Nautical Terminology:**

Port: Left side of the boat when looking forward

Starboard: Right side of the boat when looking forward

Gunwale: Upper edge of a boat's side

Leeward: Direction away from the wind

Windward: Direction from which the wind is coming

**Bow Sprit Installation:**

1. Locate the bow sprit and remove any plastic packaging or zip ties. While in the boat locate the bow sprit opening (Figure 1) on the bow of the boat.



Figure 1

2. Face the end of the bow sprit (end with the black fitting) towards the bow and lead the spinnaker tack line through the bow sprit opening (Figure 2). Tie the free end of the spinnaker tack line onto the bow eye (Figure A). This will reduce the risk of pulling the tack line out of the pole while rigging the rest of the bow sprit.

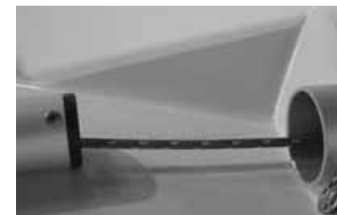

Figure 2

3. Place the sprit through the bow opening. At the opposite end of the pole the tack line exits through a sheave (Figure 3). Pull the spinnaker tack line back through the pole, until taught.



Figure 3

4. Lead the spinnaker tack line from the sheave forward, towards the bow. Lead the line clockwise through the block located on the starboard side of the sprit opening (Figure 4) and back to the Spinlock deck cleat located on the starboard side of the mast step. Ensure that the Spinlock cleat is in the "open" position by pushing forward on the top of the cleat (Figure 5 & 6). Lead the spinnaker tack line back through the cleat (front to back) and tie a stopper knot.



Figure 4

5. Take the shockcord located at the aft end of the bow sprit and lead it counterclockwise through the block located to the port side of the Spinlock cleat (Figure B). Lead the shockcord towards the bow, making sure the shockcord is underneath the spinnaker tack line. Tie off the shockcord with a stopper knot to the padeye that retains the spinnaker tack line block (Figure 7).



Figure 7

Figure A



Bow Eye

Spinnaker Tack Line  
Sheave

Bowsprit shockcord

Figure 5



Open

Figure 6



Closed

Figure B

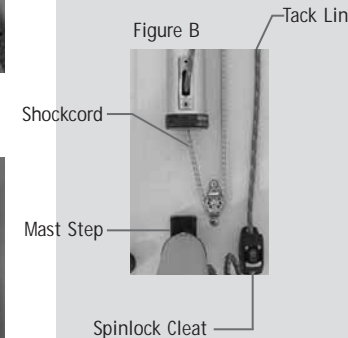

Shockcord

Mast Step

Spinlock Cleat

Tack Line



VANGUARD

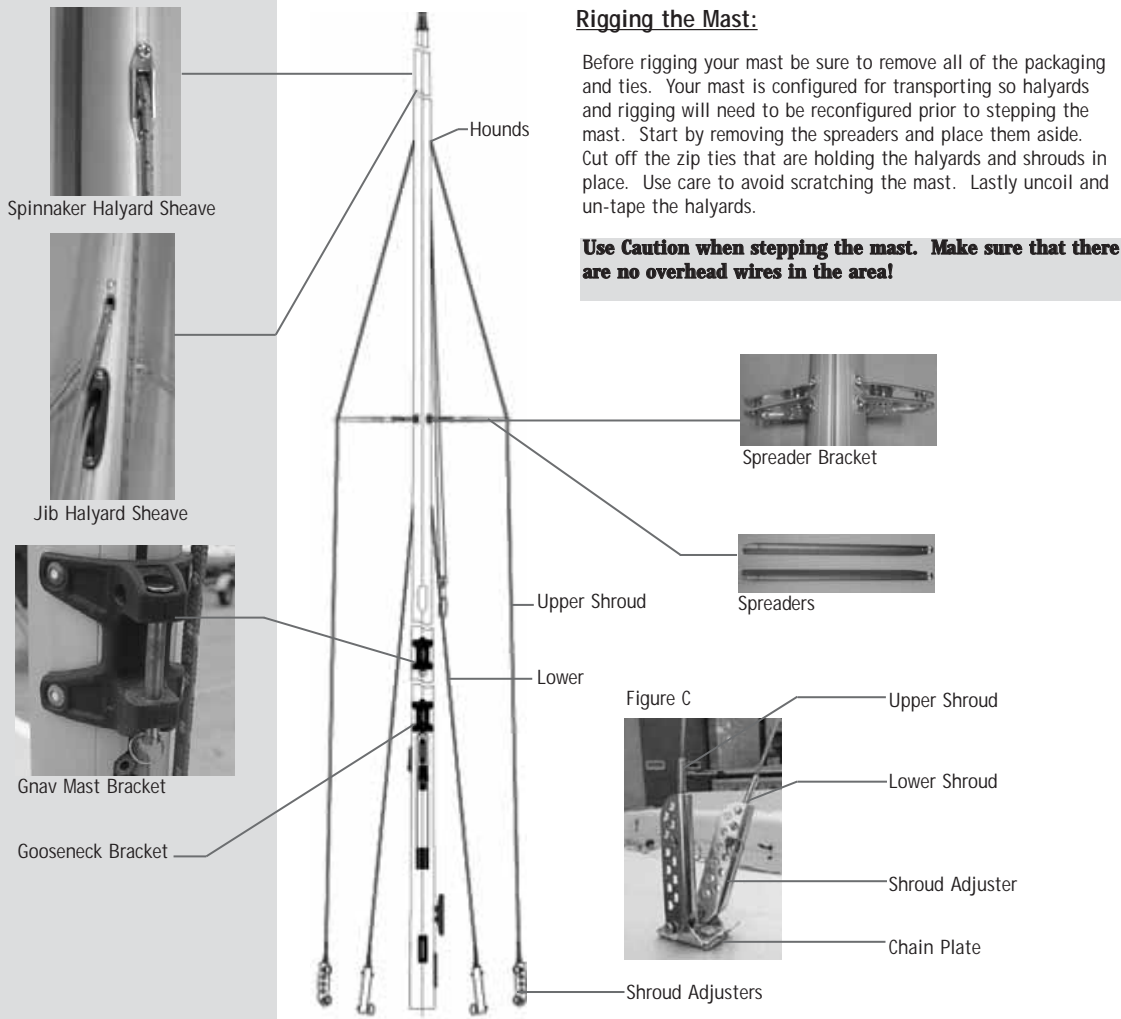

### Rigging the Mast:

Before rigging your mast be sure to remove all of the packaging and ties. Your mast is configured for transporting so halyards and rigging will need to be reconfigured prior to stepping the mast. Start by removing the spreaders and place them aside. Cut off the zip ties that are holding the halyards and shrouds in place. Use care to avoid scratching the mast. Lastly uncoil and un-tape the halyards.

**Use Caution when stepping the mast. Make sure that there are no overhead wires in the area!**

Spinnaker Halyard Sheave

Jib Halyard Sheave

Gnav Mast Bracket

Gooseneck Bracket

Hounds

Spreader Bracket

Spreaders

Upper Shroud

Lower

Figure C

Upper Shroud

Lower Shroud

Shroud Adjuster

Chain Plate

Shroud Adjusters



Figure 8

1. On the mast locate the jib halyard T-terminal (Figure 8). Install the T-terminal in the slot directly above the jib halyard sheave (Figure 9).

2. Take the end of the spinnaker halyard, coming from the exit sheave above the jib halyard terminal, and tie off to the cunningham line. The cunningham line is tied off to the gooseneck bracket.

Figure 9



Jib Halyard Sheave

3. Locate the spreader bracket on the mast (Figure 10). Locate the two spreader bars that would have been removed from the mast during un-packing. Remove the 2 sets of pins and rings from the spreader bracket. Align the holes in the spreader bracket with the holes in the spreader bar.

**Tip:** Place the pins so that the ring is on the underside of the spreader bracket. It is recommended to tape the pins and rings with electrical tape.

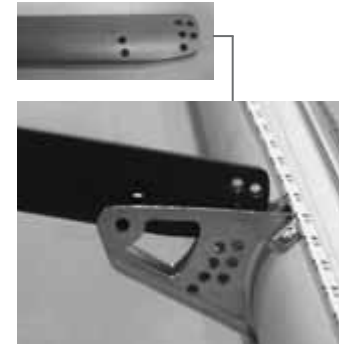

Figure 10

4. At the end of the spreader bar, locate the tip set bolt and unscrew (Figure 11).

**Tip:** Do not unscrew the bolt completely from the nut. Just unscrew it enough that the spreader tip end cap and bolt can be removed from the spreader (Figure 12)



Figure 11



Figure 12



Figure 13



Figure 14

5. Place the upper shroud into the aft notch of the spreader tip, this is the larger of the two notches (Figure 13). Align the tip to the end of the spreader and re-tighten the tip set bolt (Figure 14). Remove the slack in the shroud between the hounds and the spreader tip, prior to tightening the tip.

6. Make sure the mast carriers are attached. Walk the mast aft and rest the top of the mast in the aft mast carrier. Loosen the mast step bolt and remove (Figure 15). Align the mast heel pivot hole with the mast step hole (the second hole back). Attach the mast to the mast step with the bolt and nut (Figure 16). Use a pair of pliers and a wrench to secure the bolt tightly.



Figure 15



Figure 16



Figure 15



Figure 16

7. Take the end of the upper shroud (with the shroud adjuster) and attach it to the outer hole of the chain plate with a pin and ring. The lower shroud attaches to the inside hole of the chain plate. Repeat with other side. Refer to Figure C.



Figure 16

### Suggestions for where to place your spreader pins:

The Nomad spreaders are adjustable to allow different settings for a variety of sailing conditions. You should consider what the local weather conditions are (very windy, light, choppy, etc) before you set your spreaders. Spreaders with less sweep (greater distance between the spreaders) will make the mast stiffer whereas spreaders with more sweep (less distance between the spreaders) allow the mast to be more flexible. A more flexible mast will make the mainsail less powerful and easier to control in heavier wind conditions. Where as a stiffer mast produces more power in the mainsail which is better for lighter wind.

#### Our recommendations:

For general spreader placement start with the tip. Slide the tip all the way in so that no additional holes are showing.



Then place the spreader into the bracket. Pin the forward hole on the outer end of the bracket. The third aft hole on the outboard row is where the second pin should be positioned.

Forward hole      Outboard row



Experiment with different settings to see which may be best for you!

## Rigging the Jib Furler:



Rigged Jib Furler

In order to rig the jib furler you will need to locate the following parts from the delivery kit:

- Furler Line (located in the line bag)
- Furler Drum
- Furler drum cover with set screw
- Shackle with pin and ring ding

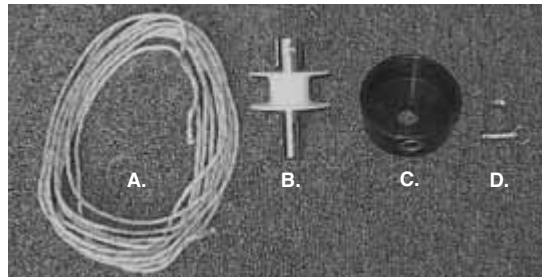

1. Lead one end of the furler line through the hole in the furler drum cover, from outside to inside (Figure 17). Lead the same end of the furler line through the hole in the furler drum, from inside to outside. Tie a stopper knot in the end of the furler line and pull it tight to the top of the furler drum.



Figure 17

2. Slide Furler drum into furler drum cover, and pull the slack out from the furler line (Figure 18).



Figure 18

3. Feed furler line onto furler drum by holding furler assembly in one hand and turning the top of the furler drum counter-clockwise with the other hand (Figure 19). Turn the furler drum counter-clockwise until the drum will not take any more of the furler line.



Figure 19

4. Turn the furler over and tighten the furler cover set-screw with a flathead screwdriver onto the furler drum shaft (Figure 20). Avoid tightening the set-screw over the slot in the furler drum shaft.



Figure 20

5. Replace the shackle with pin and ring ding provided in the delivery kit. Attach the furler assembly to the u-bolt located on the bow of the Nomad (Figure 21). Locate the jib and remove from the sail bag. Unscrew the pin from the top of the roller furler drum with a flat head screwdriver. Insert the jib tack eye into the slot on top of the jib furler drum and tighten the pin. Lead the jib furling line back to the cam cleat located on the port side of the mast step. Tie a stopper knot in the end and cleat off.



Figure 21

## General Nomad Tips

\* Check the bow sprit retractor (shock cord) for wear and tear. This is a high use application and is subject to chafe and failure. A 3/16" drill, 3/16" rivet, and rivet gun are required to replace the shockcord.

\* Before raising the mast, ensure that the lower shroud T-terminals are properly seated in the mast.

\* Before tightening the spreader tip clamp onto the side stay, pull/slide all of the slack out of the side stay between the T-terminal and the spreader tip. It is ok to have the spreader actually angled slightly up above horizontal, as the spreader will be pulled down closer to a horizontal position when the jib halyard tension is applied.

### Rigging the Jib



1. Using a flat head screwdriver, attach the jib head eye to the jib halyard swivel.

**Use Caution when stepping the mast. Make sure that there are no overhead wires in the area!**

2. Prepare to raise the mast by ensuring that the shrouds and various mast lines are clear of kinks and tangles.



3. Walk the mast up until vertical.



4. Hold the mast in the upright position. Use one hand to pull the jib halyard until the jib is fully raised. Cleat off the jib halyard in the clam cleat. Stow the tail of the halyard in the mesh bag.



### Rigging the Jib Sheets:

1. Retrieve the two jib sheets that are located in the delivery kit line bag. Locate the jib sheet cleat and bullseye fairlead on the deck.

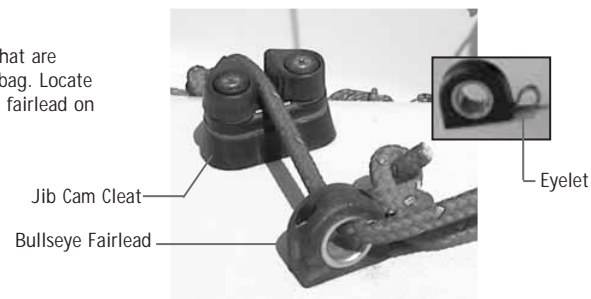

2. From the cleat side, lead the jib sheet through the fairlead and up to one of the jib clew blocks (Figure 22). Continue the line back down to the eyelet attached to the bullseye fairlead. Be sure to tie a stopper knot in the free end of the sheet.



Figure 22

3. When the jib is pulled taught, make sure that there are not any twists in the jib sheets (Figure 23). Repeat for the jib sheet on the opposite side.



Figure 23

### Rigging the Boom:

1. Locate the boom and remove any of the plastic packaging and zip ties. Remove the gooseneck pin from the mast.
2. Insert the the boom universal into the mast gooseneck bracket and attach with pin and ring. Make sure that the ring is on the underside of the boom gooseneck (Figures 24, 25 & 26).

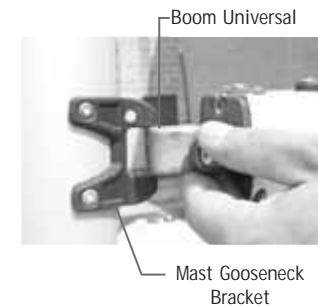

Figure 24



Figure 25



Figure 26

### Furling the Jib

1. Make sure that the jib sheets are un-cleated.
2. Slowly pull the furling line, until the jib is completely wrapped around itself.



Furling Line  
Furling Line Cleat

3. Cleat off the furling line.



4. It is suggested that you furl the jib while rigging the rest of the boat. This way you do not cause unnecessary wear and tear on the sail by flogging the jib.

### rigging the Gnav Strut:

1. Locate the Gnav Strut from the delivery kit. Insert the gnav car into the boom track opening with the block facing forward (Figure 27). Starting from the aft end of the boom, move the car towards the mast.

The Gnav car block could look like either of the images in figure 27.



Figure 27

2. Attach the gnav strut to the gnav bracket located on the mast above the gooseneck. Use the provided pin and ring to attach the strut, making sure the ring is on the underside (Figures 28, 29 & 30).



Figure 28

Figure 29

Figure 30

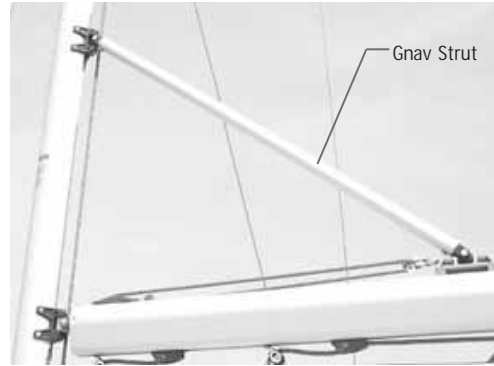
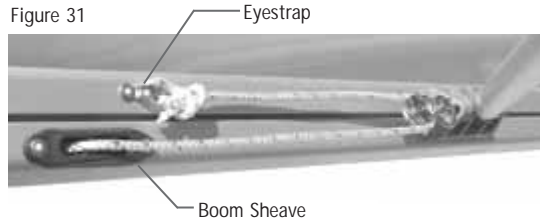

Figure 31

3. Find the sheave that is located on the top of the boom. Take the gnav line, coming from the sheave, and lead it through the gnav car block. Dead end the line with a bowline to the eyestraps (Figure 31).



4. In the delivery kit, retrieve one of the three ratchet blocks (Figure 32). Attach the block to the eyestraps located on the aft end of the boom. Use the supplied pin and ring to attach the block.

Tip: Ensure that the screws holding the eyestraps are very tight.



Figure 32

### rigging the Rudder:

1. To assemble the rudder to the tiller you will need a Phillips head screw driver and two 7/16" wrenches (or adjustable wrenches). Remove the tiller bolt from the rudder head (Figure 33).

Tip: You may use the two large plastic washers to fit between the tiller and the inside of the rudder head if needed. Often they are not needed when the boat is new, but they help make a tight fit after the boat has been sailed.

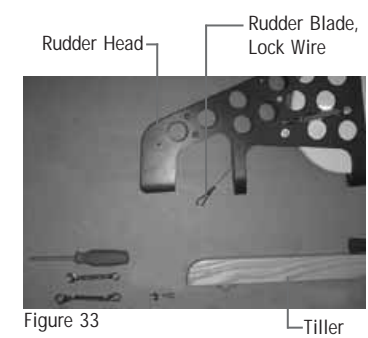

Figure 33

2. Remove one of the screws on the pad eye located on the underside of the tiller (Figure 34). Loosen the second screw a couple of turns.



Figure 34

3. Insert the tiller into the rudder head far enough to place the loop of the rudder blade lock wire over the pad eye (Figure 35).



Figure 35

4. Replace the removed screw and tighten both screws.

5. Reposition the tiller in the rudder head to align the holes. Insert the tiller bolt with one of the stainless steel washers on the outside (Figure 36).

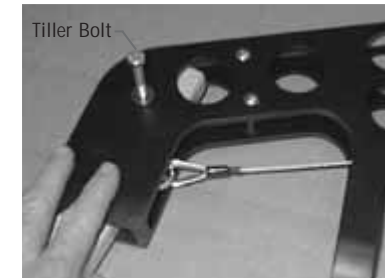

Figure 36

6. Place the second washer on the outside of the bolt and secure with the lock nut. Tighten the lock nut until it is snug (Figure 37).



Figure 37

The rudder blade may now be positioned either up or down by lifting the tiller up enough to disengage the blade lock from the blade.

7. The rudder needs to be in the upright position in order to be mounted on the pintles (Figure 38)



Figure 38

### Centerboard Control

#### Lines:

The Nomad uses a 3:1 purchase system to raise and lower the centerboard. The control lines are located on top of the centerboard trunk.



To lower the board, uncleat the uphaul line and pull on the downhaul line. The board will rotate smoothly in the trunk. Once the centerboard has been lowered, re-cleat the uphaul line.

Leave the downhaul uncleated in shallow water.

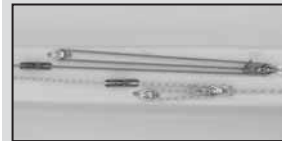

To raise the centerboard, release the downhaul line from the cleat and pull on the uphaul line. Be sure to cleat off the uphaul line to keep the board in the upright position.

Reminder: Be sure to insert and tighten the drain plug, located on the stern of the boat before going sailing!

### Bigging the Mainsheet:



Figure 38

1. Locate the mainsheet line from the delivery kit line bag. Start at the stern of the boat and locate the hole that is drilled through the transom. When standing in the cockpit it will be located to your right side. Feed the line through the hole and dead end the mainsheet under the gunwale with a stopper knot (Figure 38).



Figure 39

2. Lead the mainsheet clockwise through the ratchet block located at the end of the boom (Figure 39).

**Tip: When running the mainsheet through the ratchet block, test to make sure that you can hear a ratcheting noise. Pull the line in the direction you would while sailing and ensure that the block makes a ratcheting noise. The ratchet block may be turned on and off with the switch on one side of the block.**

### Inserting the Mainsail Battens:

1. Locate the mainsail and battens that are included in the delivery kit. There will be four battens : One short, two medium and one long in length. The shortest batten will go into the pocket closest to the head of the sail. The longest batten will go in the pocket below the shortest and lastly the two medium sized battens will follow in the additional two pockets.



Figure 40

3. Continue the mainsheet clockwise through the Harken block located on the starboard side of the boat, inside of the stern (Figure 40). Continue the mainsheet clockwise through the Harken block located in the center of the stern at the bottom of the cockpit.



Figure 41

4. Lead the mainsheet forward in the cockpit floor groove and up through the forward Harken block (Figure 41). Continue the line up through the metal column and through the mainsheet cleat. Cleat off the line and tie a stopper knot in the tail end.

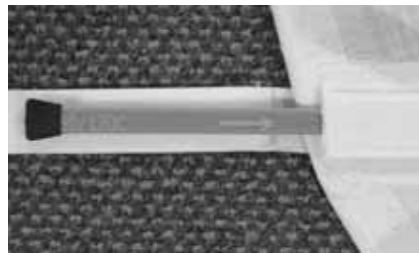

2. Locate the shortest of the four battens (compression batten). Unroll the mainsail and hold the head of the sail in your hands. Locate the shortest batten pocket at the head of the sail. Place the compression batten, tapered end first, into the pocket. The end with the black rubber tip will stick out of the end of the pocket (Figure 42 ). Secure the batten by closing off the pocket using the attached strip of velcro.

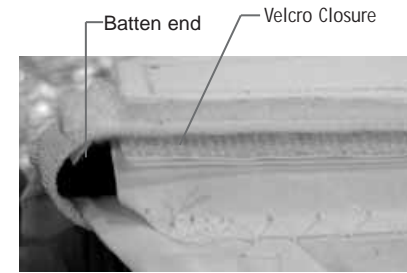

Figure 42

3. Locate the longest of the four battens and locate the longest batten pocket on the sail. Again place the batten in the pocket and push the batten until the end of it lines up to the edge of the opening (Figure 43 ).



Figure 43

4. To secure the batten in position, open the small enclosure at the end of the pocket and allow the batten end to rest in the closure (Figure 44 & 45 ).

**Tip: There will be tension against the batten when placing it in the pocket. When inserting the batten, you will be pushing against elastic located in the end of the pocket.**



Figure 44

5. Complete the sail by placing the remaining two battens in the appropriate pockets located below the long compression batten.

**Tip: The thin end of the tapered batten always goes into the batten pocket first.**



Figure 45

### Tips for Safer Sailing

\* Always wear your life jacket

\* Check the weather report prior to going sailing

\* Be sure to bring plenty of sailing gear, even if it is sunny out. You never know when you are going to get wet.

\* Wear plenty of sunscreen

\* Be sure to stay hydrated, by drinking plenty of water

\* If you have never sailed in the area before, be sure to look at a chart or ask a local sailor before setting out for sail

\* Have Fun!

**Installation of your sail floats:**

In the unlikely event of a capsizes, to prevent turning upside down, it is recommended that you purchase the Nomad sail floats through your local Vanguard dealer. The sail floats attach to the head of the sail with zippers.

To install, locate the proper float for each side of the sail and line up the corresponding zippers on the mainsail. Be sure to zip the float on completely.



**Fact or Fiction**

The Nomad was originally rigged with a C420 mast section

**Visit**

www.teamvanguard.com to submit your answer to the Nomad "Fact or Fiction" question and register to be entered into a raffle drawing!

**Rigging the Outhaul:**

1. Uncoil the outhaul that is located on the underside of the boom at the forward end (closest to the mast). Move to the aft end of the boom and locate the outhaul line that will be dead ended inside the end of the boom (Figure 46 ). Untie the knot and remove the end of the line from the boom.
2. Locate the mainsail clew slug. Feed the sail clew slug into the boom track.
3. Feed the outhaul line through the clew of the sail and then down through the outhaul fitting (Figure 47). Locate the free end of the line and tie off with a stopper knot.
4. At the forward end of the boom, tighten the outhaul until the line is taught.

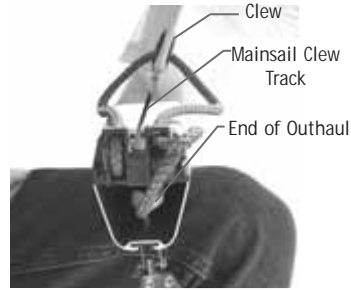

Figure 46



Figure 47

**Raising the Mainsail:**

1. Locate the tack slugs on the mainsail (Figure 48) and feed them into the mast sail track located below the gniv.



Figure 48



Figure 49



Figure 50

2. Locate the head of the sail and main halyard (the line coming off the top of the mast). Attach the main halyard to the grommet in the head of the sail with a half hitch and stopper knot (Figures 49 & 50).



Figure 51

**Tip: When raising the mainsail make sure to point the boat into the wind as well as keeping about 9 feet of clearance on either side. Also be sure that the main sheet is free of tangles.**

3. While standing on the foredeck, feed the head of the sail into the sail track just above the gniv. Pull on the main halyard to raise the sail (Figure 51).

**Rigging the Cunningham:**

1. Locate the cunningham line tied to the gooseneck fitting on the mast. Take the free end of the cunningham and lead the line through the grommet in the mainsail tack.



2. Continue the line down to the clam cleat located on the port side of the mast. Cleat off.



## Rigging the Spinnaker:

### How to pack your spinnaker:

1. Locate the clew of the spinnaker. From the clew run your hand along the colored edge of the sail until you reach the head. Along the way be sure to remove any twists or kinks that may have formed.

2. Hold the clew and the head of the sail in one hand and find the tack with your other hand.

3. Place the spinnaker in the bag with the three corners of the sail at the top of the bag. Position the tack facing toward the bow of the boat and the clew towards the stern.

4. You may now connect the halyard to the head, the tack line to the tack and the spinnaker sheets to the clew.



Figure 52



Figure 53



Figure 54



Figure 55

1. From the delivery kit, locate the two remaining ratchet blocks. With the pin and ring, attach the blocks to the eye located on the forward end of the chainplate (Figure 52 ).

2. Locate the spinnaker sheet in the delivery kit line bag. Locate the spinnaker and remove it from the provided bag. Place the spinnaker in one of the spinnaker mesh bags located next to the mast on the deck.

3. Locate the spinnaker halyard: this line exits on the mast just above the jib halyard near the top of the mast. Tie the spinnaker halyard to the head of the spinnaker with a half hitch and stopper knot (Figure 53).

**Tip:** The spinnaker is triangular shaped and has three corners which are labeled, head, tack and clew for easy recognition.

4. Untie the spinnaker tack line from the bow eye. Tie off the line to the tack grommet in the spinnaker with a bowline (Figure 54).

5. Tie one end of the spinnaker sheet into the spinnaker corner marked clew (Figure 55).

6. Lead the free end of the spinnaker sheet through the ratchet block (attached to the chainplate). Ensure that the ratchet makes a clicking noise when pulling the line through the block from the sail.

7. Continue the line through the Harken block forward of the ratchet block. Lead the spinnaker sheet across the cockpit, making sure the line is led behind the jib sheets.

8. In the reverse order, lead the spinnaker sheet through the small harken block, and then through the ratchet block. Make sure that if you pull the spinnaker sheet from the Harken block that the ratchet makes a clicking noise.

9. Continue to lead the free end of the spinnaker sheet from the ratchet block, forward around the front of the jib and continue aft insuring that the sheet is under the spinnaker tack line. Tie the free end of the spinnaker sheet onto the clew of the spinnaker.



Ratchet block  
Harken carbo block



Spinnaker sheet  
Jib sheet



Spinnaker sheet  
Tack line

### Tips on Rigging the Spinnaker:

\* The spinnaker can be rigged on either side of the jib.

\* The spinnaker sheet is one continuous line. When trimming the spinnaker just pull on the sheet that is located closest to the spinnaker

\* If the spinnaker grommet clew is not large enough to receive two sheets simultaneously, tie off one end of the sheet through the clew grommet with a bowline. Then tie off the other end of the spinnaker sheet to the bowline with another bowline.

### Using a Hoist:

Contact your local dealer in order to purchase a Nomad specific lifting bridle. The bridle has three legs, two attach to the eyes on the stern and one to the mast step, using a nut and bolt.

### Storing:

When storing your Nomad, make sure that the interior of the hull is free of water. Remove the stern drain plug. For additional ventilation you can remove the inspection port located in the forward starboard locker. Make sure that the trailer tongue is raised so that any water that might accumulate in the hull will drain out of the transom. Vanguard dealers provide a variety of Storm covers that can be used to help protect and prolong the life of your boat.

### Recommended Motor:

Additional accessories such as a motor mount can be added to your Nomad. The appropriate mounting bracket can be purchased through your local Vanguard dealer. The recommended outboard motor size is between 1-3 hp. There are several manufacturers that supply outboard motors in this size range, so it is best to choose one that suits your needs.

### Trailer Set up:

When you receive your Nomad the trailer may need to be adjusted for travel. Double check that the distance between the front edge of the trailer tongue and the front of the bow stanchion is 32". Also measure 33" from the front of the bow stanchion to the front of the bow cradle. Be sure that your Nomad is properly tied down and secured to the trailer before moving it. You will need a 1 7/8" trailer ball on your vehicle in order to attach the Nomad trailer.

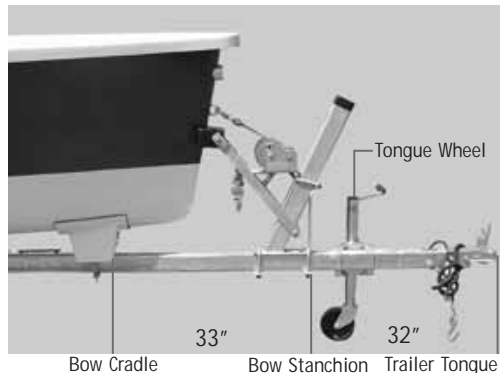

### Seitech Mast Carriers:

Two Seitech mast carriers are supplied with your boat in order to allow easier and safer transport of your mast. Locate the longer of the two carriers and use the attached U bracket and bolts to secure it to the trailer tongue. Bolt the mast carrier between the trailer bow stanchion and the front of the tongue wheel, closest to the bow stanchion. The shorter of the two mast carriers connects to the pintles on the transom of the boat. Line up the holes of the carrier over the pintles on the boat and press down over the pintles to secure. To release the aft carrier, press on the rudder lock and lift up on the mast carrier over the pintles.

### Bottom Paint:

Your Nomad is built of quality vinylester and polyester resin with fiberglass reinforcements and a balsa core. While these materials have proven to be highly durable, we encourage you to practice some standard precautions. If you intend to leave your Nomad on a mooring or in the water for extended periods of time, it will require the application of an epoxy barrier coat to all underwater surfaces including the centerboard and rudder. The application of the product should be applied correctly in accordance with the barrier coat manufacturer's instructions and specifications. Failure to do so will void Vanguards two year warranty. The application of commercially available anti-fouling bottom paint would also be recommended.

### Capsizing:

Although a very uncommon occurrence, it is possible to capsize the Nomad. The Nomad can be righted without outside assistance. The optimum weight to right a Nomad after a capsize is 450 lbs. Most often, when a capsize is imminent, the crew should get onto the centerboard as quickly as possible. The Nomad without a sail float will tend to turn completely upside down and getting onto the centerboard will help prevent this. It is best to place your weight closest to the hull, for standing too close to the tip can cause damage to the centerboard. Once on the centerboard, a retractable righting line (coming up through the deck, located by the shrouds) can be used to help move your weight further out onto the centerboard in order to pull the boat upright. It is suggested that when the boat starts to come upright on it's own, the crew member on the centerboard continues to pull down on the rail of the boat to ensure it rights completely. Once the boat is up and stable, enter the boat from the transom on either side of the rudder.

### Sail Care:

It is important to take proper care of your sails in order for them to last longer and perform to the standard that they were designed for. Follow these simple tips to help extend the life of your sails.

1. If you are sailing in salt water, be sure to rinse out your sails with fresh water after every use. Dacron and 3DL sails do not absorb water or salt but the salt will dry on the sail making them stiff. The salt in humid weather can attract moisture that may lead to mildew on your sails.
2. To wash your sails, NEVER machine wash them. Doing so will damage the material as well as remove the finish of the sail. If your sail becomes dirty, clean it with a mild dish detergent and rinse with fresh water. Do not bleach or use other harsh chemicals on the sail for they can also ruin the finish, decreasing the life of the sail. It is not recommended to store your sails wet, doing so is an invitation for mildew to grow.
3. It is not recommended to dry your sails in the sun because other than when in use, excessive exposure of UV rays will slowly break down the material of the sail. Be aware of the surface that you are drying your sails on as asphalt and other parking lot surfaces are very abrasive to the sail material and may contain chemicals (i. e. oil) that can damage the sail. Avoid hanging your sails up to dry in the breeze, unnecessary flogging will greatly reduce the life of the sail.
4. Rolling your sails is highly recommended. Crumpling a sail will crack the finish of the material which quickly reduces the life of the sail. For the mainsail start by folding the head of the sail over to the first batten pocket and roll. Keep the roll parallel to the battens all the way to the foot of the sail. As for the jib, start at the head of the sail and roll to the foot. It is not necessary to remove your battens after every use. You may want to remove the battens if you are storing the sail for an extended amount of time.
5. Make sure to regularly inspect your sails for loose or torn stitching or small tears in the cloth. Have any stitching or tears repaired by a local sailmaker before they become more of a problem.

### Sail Number Application:

Locate the hull identification number that is stamped onto the stern of the boat. This identification number will be a series of numbers and letters beginning with OQTN\_----- . There will be three numbers that follow OQTN then another letter followed by three numbers that represent the year of manufacture. The three numbers following the OQTN is the sail number. For example OQTN3011405, the sail number would be 301.

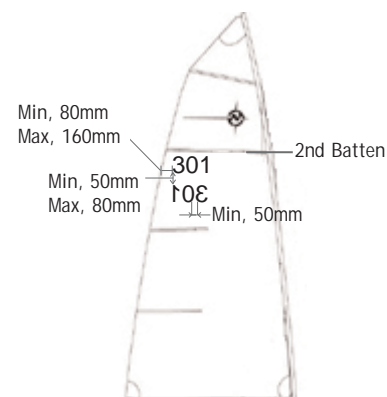

The sail numbers should be positioned below the second batten from the top, near the leech of the sail. They should also be positioned on a line parallel to the seams and all the same solid color. The sail numbers placed on the starboard side of the sail are higher.

**Enjoy your Nomad! Should you have any questions call your local dealer or Vanguard customer service at 1.800.966.SAIL**



# Owner Information



NOTES:

Hull Identification Number: OQTN \_ \_ \_ \_ \_

Purchased From: \_\_\_\_\_ Date of Purchase: \_\_\_\_\_

Contact Name: \_\_\_\_\_ Phone #: \_\_\_\_\_

Address: \_\_\_\_\_

City: \_\_\_\_\_ State: \_\_\_\_\_ Zip Code: \_\_\_\_\_

Hull Color: \_\_\_\_\_ Sail #: \_\_\_\_\_

**Registration Information (if applicable)**

Trailer VIN #: \_\_\_\_\_

License Plate Number: \_\_\_\_\_ State Register in: \_\_\_\_\_

Registration Number: \_\_\_\_\_ State Register in: \_\_\_\_\_

Insurance Information: \_\_\_\_\_

Maintenance \_\_\_\_\_

\_\_\_\_\_

\_\_\_\_\_

---



---



---



---



---



---



---



---



---



---